

## 26" Self-trimming Electric Firebox

NBDF2608

### Product Description

- 120 volt plug-in firebox with thermostat controlled fan-forced heater
- Patented electric flame technology
- Pulsating embers and LED inner glow logs molded from wood logs for incredible realism
- Clean, self-trimming design – no separate trim required
- Year-round comfort - operates with flame only or flame and heat
- Safe, clean electric operation
- Adjustable interior light and flame speed control
- 120 Volts / 1,440 Watts / 4,915 BTU



Includes on / off remote control

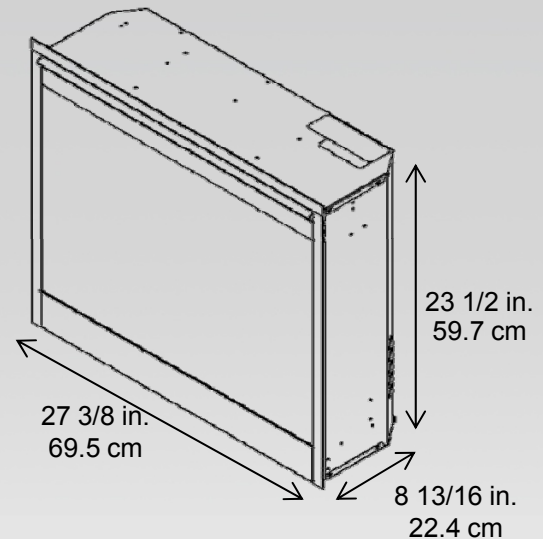
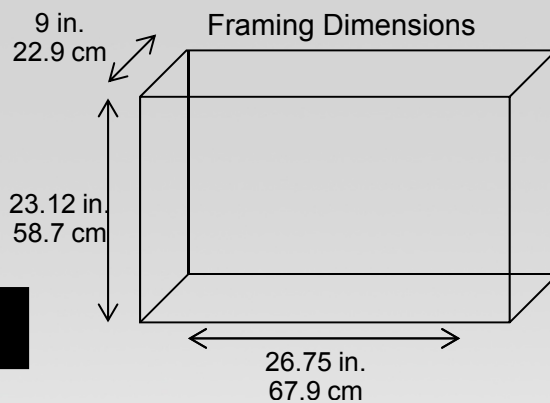

Model #	Description	lbs/kg	UPC	Wty. †	Carton Dimensions (W x H x D)		Cube	
					Inches	cm	ft <sup>3</sup>	m <sup>3</sup>
NBDF2608	26" self-trimming electric firebox.	48 / 21.8	781052 052161	2 yr.	31.6 x 26.2 x 12.4	80.3 x 66.5 x 31.5	5.9	0.17

Patent protected: for a complete list of applicable patents visit: [www.dimplex.com/patents](http://www.dimplex.com/patents). Specifications, finishes and dimensions are subject to change and should be taken as a guide only.

\* Based on average national residential electricity rates. Rates vary. † Limited warranty. © 2011 Dimplex North America Limited.